

Power and Control Isolation  
Key Exchange  
Door Locks and Actuators

» Forced Safety Key Extraction Door Interlock

DMS2E



## Forced Safety Key Extraction Door Interlock

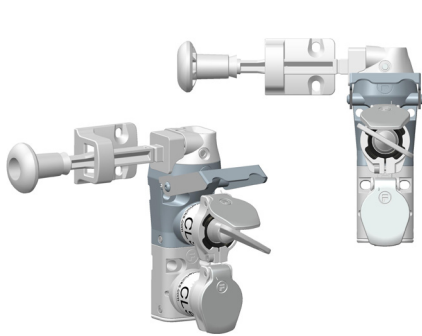

- No product handling issues:  
*4 head rotation angles with an adjustment of 360° at 90° increments with +/-5° fine adjustment*  
*Two actuator entry points*
- Stainless Steel Construction head unit
- Door will not open until safety key has been removed.
- Any combination of isolation/access keys possible
- Sequential or Non-sequential key operation
- Simply add modules to existing configurations
- Tamper resistant head mechanism
- Choice of actuator
- XMS modules can be added for system expansion
- Dust caps supplied as standard on head unit

Image shown is a DMS2E-CLIS

### mGard range

mGard is the ultimate range of robust mechanical trapped key products. Trapped key technology offers purely mechanical access locks (removing the need for expensive wiring). mGard offers an extensive variety of modular interlocking solutions. Suitable for use in applications up to SIL3 (EN/IEC 62061), Category 4 and PLe (EN/ISO 13849-1), mGard is ideal for use in harsh environments and is tested to 1,000,000 operations.

### Article Codes

N° of Locks Full Stainless Steel	Part N°
2 » 5	DMS2E » DMS5E

Lock & Key Type

Keys must be specified separately

Actuator Type

Actuator type must be specified separately

### Technical Specification

Housing Materials Body DMS	Full Stainless Steel
Head	Full Stainless Steel
Internals	Full Stainless Steel
Lock Mechanism DM	Die-cast zinc body with stainless operating mechanism (selected separately)
Lock Mechanism DMS	Full Stainless Steel
Key	Stainless Steel (purchased separately)

Product	Dimension A Overall length	Dimension B N° of slotted holes	Dimension C N° of CL locks
DMS2E	154.60	2	2
DMS3E	211.75	4	3
DMS4E	268.90	6	4
DMS5E	326.05	8	5

### Dimensional Drawing

