

## SDM230-WiFi

Single-Phase Two Module DIN rail Meters

### User Manual

2025 V1.0



- Measures kWh, kVAh, kW, kVA, PF, Hz, dmd, V, A, etc.
- Bi-directional measurement IMP & EXP
- Two pulse outputs
- WiFi Communication
- Din rail mounting 35mm
- 100A direct connection
- Better than Class 1 / B accuracy

## PART 1 Specification

### 1.1 General Specifications

- Voltage AC (Un) 230V
- Voltage Range 176~276V AC
- Base Current (Ib) 10A
- Max. Current (Imax) 100A
- Mini Current (Imin) 0.5A
- Starting Current 0.4% of Ib
- Power Consumption <2W/10VA
- Frequency 50/60Hz(±10%)
- AC Voltage Withstand 4KV for 1 minute
- Impulse Voltage Withstand 6KV-1.2uS waveform
- Overcurrent Withstand 30 Imax for 0.01s

#### Pulse Output Rate

- Pulse Output 1 1000/100/10/1 imp/Exp/kWh/kVAh (configurable)
- Pulse Output 2 1000imp/kWh (default) for import kWh
- Display LCD with white backlight
- Max. Reading 999999.9 kWh/kVAh

### 1.2 Accuracy

- Voltage 0.5% of range maximum
- Current 0.5% of nominal
- Frequency 0.2% of mid-frequency
- Power factor 1% of Unity
- Active power 1% of range maximum
- Reactive power 1% of range maximum
- Apparent power 1% of range maximum
- Active energy Class 1 IEC62053-21  
Class B EN50470-1/3
- Reactive energy Class 2 IEC62053-23

### 1.3 Environment

- Operating temperature -25°C to +55°C
- Storage and transportation temperature -40°C to +70°C
- Reference temperature 23°C±2°C
- Relative humidity 0 to 95%, non-condensing
- Altitude up to 2000m
- Warm up time 5s
- Installation category CAT III
- Mechanical Environment M1
- Electromagnetic environment E2
- Degree of pollution 2

### 1.4 Output

#### Pulse Output

The meter provides two pulse outputs. Both pulse outputs are passive type.

Pulse output 1 is configurable. The pulse output can be set to generate pulses to represent total / import/export kWh or kVAh.

The pulse constant can be set to generate 1 pulse per: 0.001(default) / 0.01/0.1/kWh/kVAh.

**Pulse width:** 200/100/60ms

Pulse output 2 is non-configurable. It is fixed to import kWh. The constant is 2000imp/kWh.

**Wi-Fi support:** 2.4Ghz b/g/n

**Wi-Fi data freq.:** Every second

## 1.5 LCD display



## PART 2 Operation

### 2.1 Initialization Display

When powered, the meter will initialize and self check.

ΣT8IMPEXPMD1.1.1.2 888.88.8.8 PF Hz MkVAh MkWh Signal bars	Initialize
70 04.04	Software version
EE 0393	Software number
TESTING	Self testing
AP	AP distribution network

### 2.2 Signal symbol

Signal bars	The signal bar on the display interface indicates the network strength and status, while connected, you will see between 0-6 bars indicating signal strength. If the signal bar is flashing simultaneously with 6 bars then this means the meter is not connected to the network.
ERR	Failed to connect to WiFi module

### 2.3 Scroll display by Button

After initialization and the self-checking program has run, the meter will display the measured values. The default page is the total kWh. If the user would like to check other information, they should press the WIFI button to scroll through the other pages.

#### The display order by scroll button:

Total kWh → import kWh → export kWh → resettable kWh → total kVAh → import kVAh → export kVAh → resettable kVAh → Max. power demand → voltage → current → W → VA → VA → power factor → frequency → running time → server time → Version number of ESP32

### 2.4 Start-up Screens

Σ 00070.00 kWh	Total active energy Example: 70.00kWh
IMP 00050.00 kWh	Import active energy Example: 50.00kWh
EXP 00020.00 kWh	Export active energy Example: 20.00kWh
Σ r 00002.68 kWh	Total resettable energy
Σ 00010.00 kVAh	Total reactive energy Example: 10.00kVAh
IMP 00005.00 kVAh	Import reactive energy Example: 5.00kVAh

EXP 00005.00 kVAh	Export reactive energy Example: 5.00kVAh
Σ r 00001.49 kVAh	Total resettable reactive energy
Σ MD 6930 W	Total Max. power demand Example: 6930W
229.8 V	Voltage Example: 229.8V
30.156 A	Current Example: 30.156A
4700 W	Active Power Example: 4700W
1030 VA	Reactive Power Example: 1030VA
4811 VA	Apparent power Example: 4811VA
1.000 PF	Power factor Example: 1.000
49.99 Hz	Frequency Example: 49.99Hz
Σ 0.1h	Running time Example: 0.1h
01:01:01	Server time Example: 01:01:01 Note: If not connected to the server, the meter will display offline
ESP04.04	Version number of ESP32 Example: ESP04.04

### 2.5 Set-up Mode

To get into Set-up Mode, the user need press the 'Scroll button' button for 3 second.

Good	The setting is done correctly
Err	The entering information is wrong. The operation fails.
PAS 0000	Password To get into set up mode, you will need to enter the default password below. Default password: 1000
PLS OUT	Pulse Output Default: Export kWh Option: kWh / kVAh / Imp. kWh / Exp.kWh / Imp.kVAh / Exp.kVAh
PLS OUT	Hold down the 'Enter' button, the red text will flash. Press the 'Scroll' button to change the type. After selecting the new pulsed output type, the user should hold down the 'Enter' button to confirm the setting.
PLS cSt	Pulse Constant Default: 1000 Option: 1000 / 100 / 10 / 1
cSt 1000	Hold down the 'Enter' button, the red text will flash. Press the 'Scroll' button to change the option. After selecting the new pulse constant option, the user should hold down the 'Enter' button to confirm the setting.

PLS t	Pulse duration Default: 100ms Option: 200 / 100 / 60ms
PLSt 200	Hold down the 'Enter' button, the red text will flash. Press the 'Scroll' button to change the option. After selecting the new pulse duration option, the user should hold down the 'Enter' button to confirm the setting.
dIt 5Et	Demand Integration Time Default: 15 minutes Option: 5 / 10 / 15 / 30 / 60 / OFF
dIt 15	Hold down the 'Enter' button, the red text will flash. Press the 'Scroll' button to change the option. After selecting the new DIT option, the user should hold down the 'Enter' button to confirm the setting.
ScRL t	Automatic Scroll Time Interval Default: 0 S Option: 0 ~ 255S
t 30 S	Hold down the 'Enter' button, the red text will flash. Press the 'Scroll' button to change the option. After selecting the new scroll time option, the user should hold down the 'Enter' button to confirm the setting.
LP 5Et	Backlight duration timer set-up Default: 60 min Option: 0 (OFF) / 5/ 10/ 20/ 30/ 60 Hold down the 'Enter' button to enter set-up mode.
LP 60	Press the 'Scroll' button to change the backlight time. After selecting the new backlight option, the user should hold down the 'Enter' button to confirm the setting.
CLr	Clear Hold down the 'Enter' button to enter clear interface.
MD CLr	To clear the Max demand reading for active power, hold down the 'Enter' button.
Σ r CLr	To clear the resettable energy readings, hold down the 'Enter' button.
SEt PASS	Password Default: 1000
PAS 1000	Hold down the 'Enter' button, the red text will flash. Press the 'Scroll' button to change the values. After selecting the new password, hold down the 'Enter' button to confirm the setting.
AP nODE	AP mode Hold down the 'Enter' button to enter AP mode setting.
SEt	Hold down the 'Enter' button to set the AP mode.
UPdAtE	Online update function Hold down the 'Enter' button to set the AP mode.
nEtEN	Online update function Two options: Meter: Meter update ESP32: wifi module update
Good	After all settings are completed Good: Good means the setting was successful ERR: ERR means the setting was unsuccessful
ERR	

## 2.6 Wiring Diagram

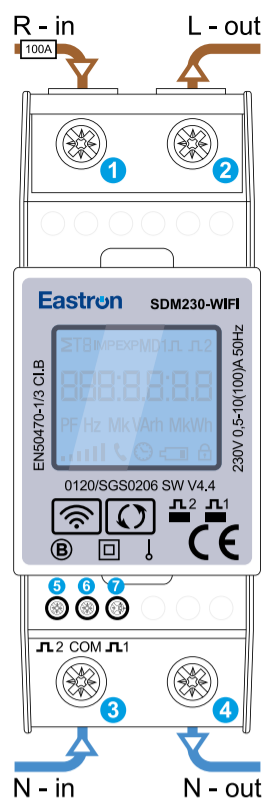

## 2.11 Pulsed output type

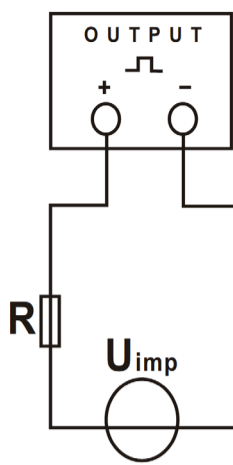

The test pulse output is a polarity dependant, passive transistor output requiring an external voltage source for correct operation. For this external voltage source, the voltage ( $U_i$ ) should be 5-27V DC, and the maximum input current ( $I_{max}$ ) should be 27mA DC. To connect the impulse output, connect 5-27V DC to connector 7 (anode) and the signal wire (s) to connector 6 (cathode). The meter pulse is indicated on the front panel by a red flashing LED

**ATTENTION:** Pulse output must be fed as shown in the wiring diagram above. Scrupulously respect polarities and the connection mode. Opto-coupler with potential free SPST-NO contact.

Contact range: 5-27V DC Max current input: 27mA DC

## 2.7 Dimensions

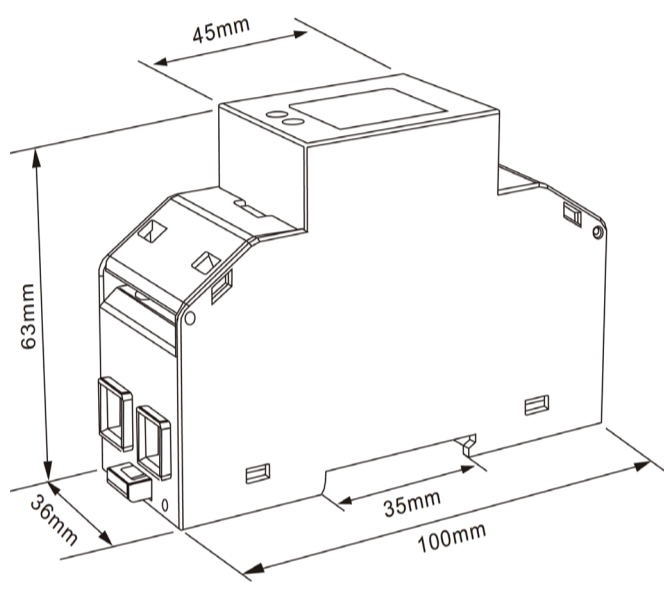

## 2.8 Installation

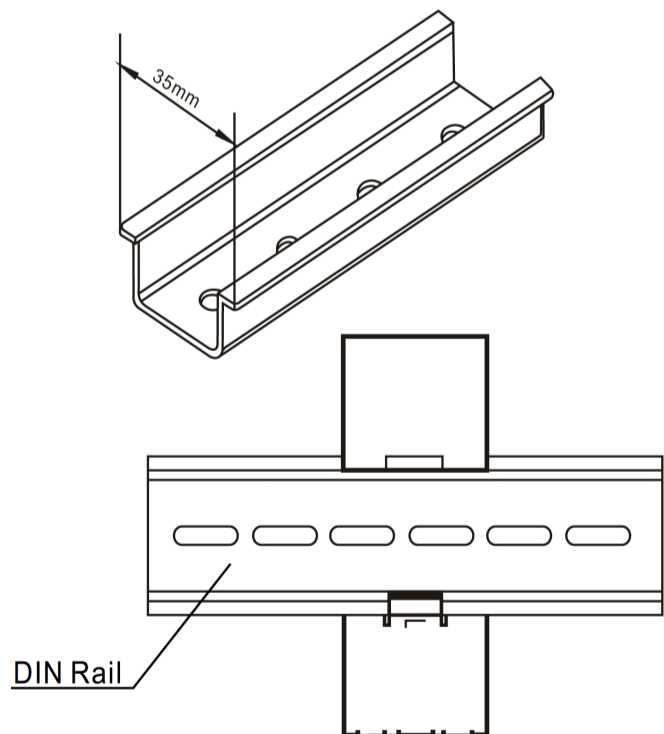

## 2.9 Wiring Torque

Terminals Capacity	COMM / Pulse / 2T	0.5-1.5mm <sup>2</sup>
	Load	4-25mm <sup>2</sup>
Screw Torque	COMM / Pulse / 2T	0.4Nm
	Load	2.5Nm-3Nm

## 2.10 Mechanics

- Din rail dimensions 36x100x63 (WxHxD) Per DIN 43880
- Mounting DIN rail 35mm
- Ingress protection IP51 (indoor)
- Material Self-extinguishing UL94V-0

## EU Type Examination Certificate



<b>SGS</b>	EU-Type Examination Certificate Number:	
	<b>0120/SGS0206</b>	
	Issue Number: 9	Dated: 20 <sup>th</sup> October 2023
<b>1. Technical Data</b>		
Manufacturer	Zhejiang Eastron Electronic Co., Ltd.	
Meter Type(s)	SDM230-Modbus, SDM230-BI, SDM230-DR, SDM230-Pulse, SDM230-Mbus V1, SDM230-Mbus V2, SDM230-TT, SDM230-CT, SDM230-CT, SDM230-Lora, SDM230-WIFI, SDM230-NMI, SDM230-NM-2	
Voltage Rating (Un)	230V	
Current Rating (I <sub>min</sub> - I <sub>ref</sub> (max))	0.5-10/100A	
Frequency (Hz)	50Hz	
Active Accuracy Class (kWh)	A or B (kWh)	
Type of circuit	1φ2w	
Temperature Range	-25°C to +55°C	
Software Version No's	SDM230-Modbus, SDM230-BI, SDM230-DR, SDM230-Pulse: V1.2 SDM230-TT: V1.3 SDM230-CT: V1.3 SDM230-Mbus V1, SDM230-Mbus V2: V1.2 SDM230M-DI: V1.1 SDM230-Lora: V2.3 SDM230-WIFI: V4.4 SDM230-NMI: V1.3 SDM230-NM-2: V1.6	
Checksum No's	SDM230-Modbus, SDM230-BI, SDM230-DR, SDM230-Pulse: 0x00005F2 SDM230-TT: 0x0000A25 SDM230-Mbus V1, SDM230-Mbus V2: 0x0000423 SDM230M-DI: 0x2547 SDM230-Lora: 0x81F2 SDM230-WIFI: 0xD712 SDM230-NMI: 0xFF9F54 SDM230-NM-2: 0xF10BED	
Identification Location	Nameplate	
Bill of Materials No's	SDM230-Modbus, DH-JS-100040 V1.6 SDM230 BI, SDM230 DR, SDM230 Pulse, DH-JS-150051 V1.6 SDM230-TT, DH-JS-150059 V1.0 SDM230-Mbus V1, DH-JS-150017 V1.0 SDM230-Mbus V2, DH-JS-150029 V1.0 SDM230M-DI, DH-JS-200012 V1.3 SDM230-Lora, DH-JS-200016 V1.6 SDM230-WIFI, DH-JS-150042 V1.6 SDM230-NMI, DH-JS-210017 V1.2 SDM230-NM-2, DH-JS-210027 V1.3	
IP Rating	IP51	
Insulation Protective Class	Class II	
LED Pulse Constant	1000imp/kWh	
Impulse Voltage Rating	8kV	
AC Voltage Rating	8kV	
Terminal Cover Sealing Type	4 x Wire & Crimp	
Integrity of meter	Inaccessible without breaking seals	
Intended Location of the Meter	Indoor	
Type of Register	LCD	

## Declaration of Conformity

(for the MID approved version meter only)  
We Zhejiang Eastron Electronic Co.,Ltd. Declare under our sole responsibility as the manufacturer that the single phase multi-funton electrical energy meter "SDM230 Series" correspond to the production model described in the EU-type examination certificate and to the requirements of the Directive 2014/32/EU EU type examination certificate number 0120/SGS0206. Identification number of the NB0598



EasyLink

Download the EasyLink App on Apple and Play Store



## Safety Instruction

The Installation instructions do not include a complete list of all safety measures necessary for operating the device. Special operating conditions may require additional measures. The installation instructions contain notes that must be observed for your personal safety to prevent property damage.

Safety instructions in this document are highlighted with a warning triangle and are presented as follows depending on the level of risk.



The General warning symbol calls attention to possible risks of injury. Observe all the instructions listed under the symbol to prevent injuries or even death



This additional symbol indicates any electrical danger that can result in serious injuries or death

## Attention

Warns of an imminently dangerous situation that can result in property damage or environmental damage in the event of non-compliance.

**Misrepresentation Act** - The details provided in this document are believed to be accurate but cannot be guaranteed. All liability, whether in negligence or otherwise, for any loss arising from the use of these details is hereby excluded.

©2025 Copyright Eastron.

## CONTACT US

If you have any question, please feel free to contact our sales team.

Address: **NO 52, Dongjin Road, Nanhu, Jiaxing, Zhejiang, China**

Tel: **+86-573-83698881**

Email: **sales@eastrongroup.com**

Fax: **+86-573-83698883**

[www.eastrongroup.com](http://www.eastrongroup.com)

**Eastron**