

SDM630-WiFi

Three-Phase Four Module DIN rail Meters

User Manual

2025 V1.0



1. Introduction

This document provides operating, maintenance and installation instructions. These units measure and display the characteristics of single phase two wires(1P2W), three phase three wires(3P3W) and three phase four wires(3P4W) networks. The measuring parameters include voltage (V), frequency (Hz), current (A), power (kW/kVA/kVAh), import, export and total energy (kWh/kVAh). The units can also measure maximum current demand and power demand, this is measured over preset periods of up to 60 minutes.

These units are Max. 100A direct connected and do not need to connect with external current transformers(CT). The unit is built-in with pulse,WIFI outputs. Configuration is password protected.

2. Specification

2.1 Measured Parameters

The unit can monitor and display the following parameters of a single phase two wires (1P2W), three phase three wires (3P3W) or three phase four wires (3P4W) system.

2.2 Voltage and Current

- Phase to neutral voltages 176 to 276V a.c.(not for 3p3w supplies).
- Voltages between phases 304 to 480V a.c.(3p supplies only).
- Percentage total voltage harmonic distortion (THD%) for each phase to N (not for 3p3w supplies).
- Percentage voltage THD% between phases (three phase supplies only).
- Current THD% for each phase.

2.3 Power Factor and Frequency and Max. Demand

- Frequency in Hz
- Power factor
- Instantaneous power: Power 0 to 99999 W
- Reactive power 0 to 99999 VAR/Volt-amps 0 to 99999 VA
- Maximum demand power since last reset
- Maximum neutral demand current, since the last reset (for three phase supplies only)

2.4 Energy Measurements

- Import active energy 0 to 999999.99 kWh
- Export reactive energy 0 to 999999.99 kVAh
- Import active energy 0 to 999999.99 kWh
- Export reactive energy 0 to 999999.99 kVAh
- Total active energy 0 to 999999.99 kWh
- Total reactive energy 0 to 999999.99 kVAh

2.5 Measured Inputs

Voltage inputs through 4-way fixed connector with 25mm² stranded wire capacity. single phase two wires (1p2w), three phase three wires (3p3w) or three phase four wires (3p4w) unbalanced. Line frequency measured from L1 voltage or L3 voltage.

- Voltage AC(Un) 3x230(400)V
- Voltage Range 80~120%Un
- Base Current (Ib) 10A AC
- Max.Current (Imax) 100A AC
- Min.Current (Imin) 0.3A
- Starting current 0.4%of Ib
- Power consumption ≤2W/10VA for the voltage measuring circuit
≤4VA for the current measuring circuit

2.6 Accuracy

- Voltage 0.5% of range maximum
- Current 0.5% of nominal
- Frequency 0.2% of mid-frequency
- Power factor 1% of unity (0.01)
- Active power (W) ±1%of range maximum
- Reactive power (VAR) ±1%of range maximum
- Apparent power (VA) ±1%of range maximum
- Active energy (Wh) Class 0.5 IEC 62053-21; Class C EN 50470-3:2022 (MID version)
Class 2 IEC 62053-23
- Reactive energy (VAh) Class 2 IEC 62053-23
- Response time to step input 1s,typical,to >99%offinal reading,at 50 Hz.

2.7 Measured Inputs

Influence Quantities are variables that affect measurement errors to a minor degree.Accuracy is verified under nominal value (within the specified tolerance)of these conditions.

- Ambient temperature 23°C±2°C
- Input frequency 50 or 60Hz±2%
- Input waveform Sinusoidal (distortion factor<0.005)
- Magnetic field of external origin Terrestrial flux

2.8 Environment

- Operating temperature -40°C to +70°C
- Storage temperature -40°C to +70°C
- Relative humidity 0 to 95%,non-condensing
- Altitude Up to 2000m
- Warm up time 5s
- Vibration 10Hz to 50Hz, IEC 60068-2-6,2g 30g in 3 planes
- Shock

*Maximum operating and storage temperatures are in the context of typical daily and seasonal variation.

2.9 Mechanics

- DIN rail dimensions 100x72x66mm (WxHxD) per DIN 43880
- Mounting DIN rail (DIN35mm)
- Ingress protection IP51(indoor)
- Material Self-extinguishing UL94 V-0

2.10 Pulse Output

The meter is equipped with pulse output, which is fully isolated from the inside circuit. That generates pulses in proportion to the measured energy. The pulse output is polarity dependent, passive transistor output requiring an external voltage source for correct operation.

For this external voltage source, the voltage shall be 5-27V DC, and the maximum input current shall be 27mA DC.

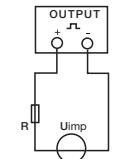

ATTENTION: Pulse output must be fed as shown in the wiring diagram on the left. Scrupulously respect polarities and the connection mode. Opto-coupler with potential-free SPST-NO Contact.

Contact range: 5~27VDC
Max. current input: 27mA DC

Pulse Output

The meter provides two pulse outputs. Both pulse outputs are passive type.

Pulse output 1 is configurable. The pulse output can be set to generate pulses to represent total / import / export kWh or kVAh.

The pulse constant can be set to generate 1 pulse per: 0.001(default) / 0.01 / 0.1 / 1kWh/kVAh.

Pulse width: 200/100/60ms

Pulse output 2 is non-configurable. It is fixed to import kWh. The constant is 2000imp/kWh.

Wi-Fi support: 2.4Ghz b/g/n

Wi-Fi data freq.: Every second

2.11 LCD Display

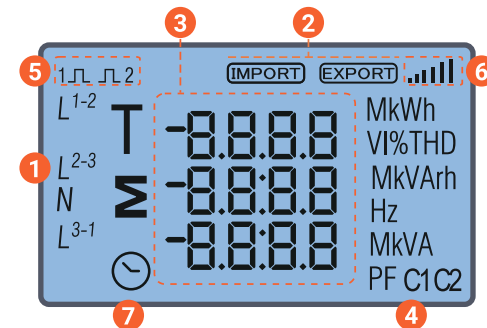

Item	Descriptions
1	Total, fases or sum
2	Import or Export energy
3	Measured value (8 digits)
4	Measurement units
5	Pulse 1 and 2
6	Wi-Fi signal strength
7	Time identifier

3. Operation

3.1 Start Up Screens

The first screen lights up all display segments and can be used as a display check.

Software version information

Program number information

The interface performs a self-test and indicates there suit if the test passes.

*After a short delay, the screen will display active energy interface as follows:

Total active energy in kWh.

3.1 Measurements

The buttons operate as follows:

- Selects the Voltage and Current display screens. In Set-up Mode, this is the "Left" or "Back" button.
- Select the Frequency and Power factor display screens. In Set-up Mode, this is the "Up" button.
- Select the Power display screens. In Set-up Mode, this is the "Down" button.
- Select the Energy display screens. In Set-up mode, this is the "Enter" or "Right" button.

3.2 Voltage and Current

Each successive press of the button selects a new parameter:

Phase to neutral voltages. *Not available under 3P3W

Phase to phase voltages. *Not available under 1P2W

Current on each phase.

Phase to neutral voltage THD%

Current THD% for each phase

3.3 Frequency and Power Factor and Demand

Each successive press of the button selects a new range:

Frequency and Power Factor (total).

Power Factor of each phase. *Not available under 3P3W, 1P2W.

Maximum Current Demand.

Maximum Power Demand.

*Hold the button for 3s to check the COMM. Setting, software version, CRC and full display pages.

3.4 Power

Each successive press of the button select a new range:

Instantaneous Active Power in kW. *Not available under 3P3W, 1P2W.

Instantaneous Reactive Power in kVAh. *Not available under 3P3W, 1P2W.

Instantaneous Volt-Amps in kVA. *Not available under 3P3W, 1P2W.

Total kW, kVAh, kVA.

3.5 Energy Measurements

Each successive press of the button selects a new range:

Total active energy in kWh.

Total reactive energy.

Import active energy in kWh. *Not shown on tariff models.

Export active energy in kWh. *Not shown on tariff models.

Import reactive energy. *Not shown on tariff models.

Export reactive energy. *Not shown on tariff models.

3.6 WIFI Connection Mode

This screen displays four states of WIFI connection

AP distribution network

WiFi mode

Time

Report data

Time

Report interval

WiFi firmware

3.7 Set Up

To enter set-up mode, press the button for 3 seconds until the password screen appears.

Setting up is password-protected. The user must enter the correct password (default "1000") before processing.

If an incorrect password is entered, the display will show: PASS ERR

To exit setting-up mode, press repeatedly until the measurement screen is restored.

3.8 Set-up Entry Methods

Some menu items, such as password, require a four-digits number entry while others, such as supply system, require selection from a number of menu options.

3.8.1 Menu Option Selection

1. Use the and buttons to scroll through the different options of the set up menu.
2. Press to confirm your selection.
3. If an item flashes, then it can be adjusted by the and buttons.
4. Having selected an option from the current layer, press to confirm your selection.
5. Having completed a parameter setting, press to return to a higher menu level, and you will be able to use the and buttons for further menu selection.
6. On completion of all setting-up, press repeatedly until the measurement screen is restored.

3.8.2 Number Entry Procedure

When setting up the unit, some screens require the entering of a number. In particular, when entry to the setting up section, a password must be entered. Digits are set individually, from left to right. The procedure is as follows:

1. The current digit to be set flashes and is set using the and buttons.
2. Press to confirm each digit setting.
3. After setting the last digit, press to exit the number setting routine.

3.9 Pulse Output

This option allows you to configure the pulse output 1. The output can be set to provide a pulse for a defined amount of energy active or reactive. Use this section to set up the pulse output for:

Total kWh/Total kVAh
Import kWh/Export kWh
Import kVAh/Export kVAh

From the set-up menu, use and buttons to select the pulse output option.

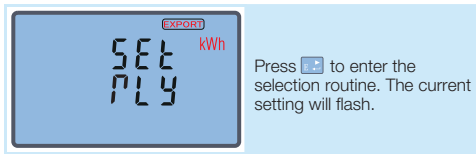

Press **[F1]** to enter the selection routine. The current setting will flash.

Press **[F2]** to confirm the setting and press **[F3]** to return to the main set up menu.

3.10 Pulse Rate

Use this to set the energy represented by each pulse. Rate can be set to 1 pulse per dFt / 0.01 / 0.1 / 1 / 10 / 100kWh/kVArh.



(It shows 1 pulse = 10kWh/kVArh)



From the set-up menu, use **[F1]** and **[F2]** buttons to select the pulse rate option.



Press **[F2]** to enter the selection routine. The current setting will flash. When it's dFt(default), it means 2.5Wh/VArh.

Use **[F1]** and **[F2]** buttons to choose pulse rate, then press **[F2]** to confirm the setting and press **[F3]** to return to the main set up menu.

3.11 Pulse Duration

The pulse width can be selected as 200, 100 (default) or 60ms.



(It shows pulse width of 100ms)



From the set-up menu, use **[F1]** and **[F2]** buttons to select the pulse width option.



Press **[F2]** to enter the selection routine. The current setting will flash.

Use **[F1]** and **[F2]** buttons to choose pulse rate, then press **[F2]** to confirm the setting and press **[F3]** to return to the main set up menu.

3.12 DIT Demand Integration Time

This sets the period in minutes over which the current and power readings are integrated for maximum demand measurement. The options are:0,5,8,10,15,20,30,60 minutes.

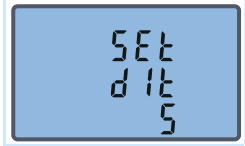

From the set-up menu, use **[F1]** and **[F2]** buttons to select the DIT option. The screen will show the currently selected integration time.



Press **[F2]** to enter the selection routine. The current time interval will flash.

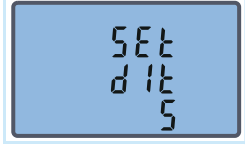

Use **[F1]** and **[F2]** buttons to select the time required. Press **[F2]** to confirm the selection.

Press **[F3]** to exit the DIT selection routine and return to the menu.

3.13 Backlit Set-up

Backlit lasting time is settable, default lasting time is 60 minutes.



It is set as 5, the backlit will be off in 5 minutes if there is no more further operation.



Press **[F2]** to enter the selection routine. The current time interval will flash. The options are: 0(always on)/5/10/30/60/120

Press **[F1]** and **[F2]** to select the time interval. Then press **[F2]** to confirm the set-up.

3.14 Supply System

The unit has a default setting of 3 phase 4 wires (3P4W) Use this section to set the type of electrical system.

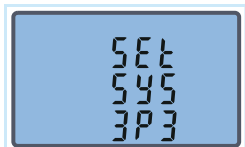

From the set-up menu, use **[F1]** and **[F2]** buttons to select the system option. The screen will show the currently selected system type.



Press **[F2]** to enter the selection routine. The current selection will flash.



Use **[F1]** and **[F2]** buttons to select the required system option: 1P2(W),3P3(W), 3P4(W). Press **[F2]** to confirm the selection.

Press **[F3]** to exit the system selection routine and return to the menu.

3.15 CLR

The meter provides a function to reset the maximum demand value of current and power.



From the set-up menu, use **[F1]** and **[F2]** buttons to select the reset option.



Press **[F2]** to enter the selection routine. The MD will flash.

Press **[F2]** to confirm the reset and press **[F3]** to return to the main set up menu.

3.16 Change Password



Use the **[F1]** and **[F2]** to choose the change password option.



Press **[F2]** to enter the change password routine. The new password screen will appear with the first digit flashing.



Use the **[F1]** and **[F2]** to set the first digit and press **[F2]** to confirm your selection. The next digit will flash.



Repeat the procedure for the remaining three digits. After setting the last digit, press **[F2]** to confirm the selection.

Press **[F3]** to exit the number setting routine and return to the menu.

3.17 AP Mode



AP Mode



Long press **[F2]** to enter AP mode.



Exit AP mode.

3.18 Upgrade



Upgrade Configuration



Long press **[F2]** to choose to upgrade the electric meter or ESP32 module online.



WiFi module upgrad

4. Installation

4.1 Safety Instruction

Information for Your Own Safety

Important safety information is contained in the maintained section. Familiarize yourself with this information before attempting installation or other procedures. Symbols used in this documents:



Risk of Danger

This means to call attention to a high risk, for example: "High voltage". Failure to observe the instruction can result in death, serious injury or considerable material damage.



Caution

This means hazard of electric shock and failure to take the necessary safety precautions will result in death, serious injury or considerable material damage.

Qualified Personnel

Operation of the equipment (module, device) described in this manual may only be performed by qualified personnel. Qualified personnel in this manual means person who are authorized to commission, start up, ground and label devices, systems and circuits according to safety and regulatory standards. The installer is responsible for coordinating the rating and the characteristics of the supply side overcurrent protection devices with the maximum current rating and, in the case of direct connected meters, with the UC rating of the metering equipment.

Proper Handling

The equipment (device, module) may only be used for the application specified in the catalogue and the user manual, and only be connected with devices and components recommended and approved by EASTRON.

- The unit does not have internal fuses therefore external fuses must be used for protection and safety under fault conditions.
- Use only insulating tools.
- Do not connect while circuit is live (hot).
- Place the meter only in dry surroundings.
- Do not mount the meter in an explosive area or expose the meter to dust, mildew and insects.
- Make sure the used wires are suitable for the maximum current of this meter.
- Make sure the AC wires are connected correctly before activating the current / voltage to the meter.
- Do not touch the meter connecting clamps directly with your bare hands, with metal, blank wire or other material as you may get an electrical shock.
- Make sure the protection cover is placed after installation.
- Installation, maintenance and reparation should only be done by qualified personnel.
- Never break the seals and open the front cover as this might influence the functionality of the meter, and will avoid any warranty.
- Do not drop, or allow physical impact to the meter as there are high precision components inside that may break.
- An external switch or circuit-breaker should be installed on the power supply wires, which will be used to disconnect the meter and the device supplying energy. It is recommended that this switch or circuit-breaker is placed near the meter because that is more convenient for the operator. The switch or circuit-breaker must comply with the specifications of the building' selectrical design and all local regulations

4.2 Maintenance

In normal use, little maintenance is needed. As appropriate for service conditions, isolate electrical power, inspect the unit and remove any dust or other foreign material present. Periodically check all connections for freedom from corrosion and screw tightness, particularly if vibration is present. The front of the case should be wiped with a dry cloth only. Use minimal pressure, especially over the viewing window area. If necessary wipe the rear case with a dry cloth. If a cleaning agent is necessary, isopropyl alcohol is the only recommended agent and should be used sparingly. Water should not be used. If the rear case exterior or terminals should be contaminated accidentally with water, the unit must be returned to EASTRON for inspection and testing

5. Dimensions

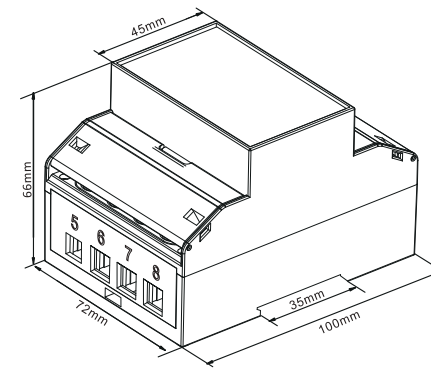

6. Wiring Diagram

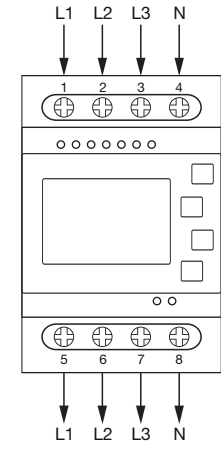

Three Phase Four Wires

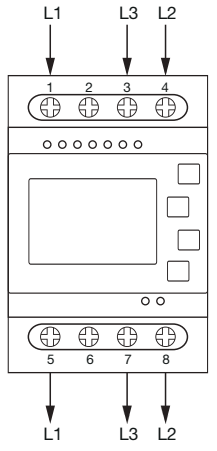

Three Phase Three Wires

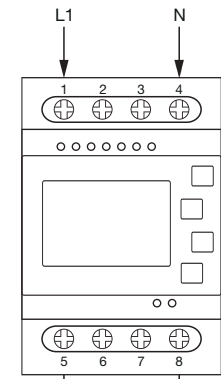

Single Phase Two Wires

* For reverse wiring needs, kindly notify our sales team before placing an order

Terminals		
COMM/Pulse/2T	0.5-1.5mm ²	0.4Nm
Load	4-25mm ²	2.5-3Nm

7. Declaration of Conformity (for the MID approved version meter only)

We Zhejiang Eastron Electronic Co.,Ltd. Declare under our sole responsibility as the manufacturer that the poly phase multifunction electrical meter "SDM630-WIFI" correspond to the production model described in the EU-type examination certificate and to the requirements of the Directive 2014/32/EU. Type examination certificate number MID T 12801. Identification number of the NB0122.

EU Declaration of Conformity

We, Zhejiang Eastron Electronic Co.,Ltd (Company Name)
No.52,Dongjin Road,Nanhu,Jiaxing,Zhejiang,China (Company Address)

Ensure and declare that electricity meter types:
SDM630-WIFI
With the measurement range
3*230/400V,0.3-10(100)A,50HZ/60HZ,400imp/kWh

Are in conformity with the type as described in the
EU-type examination certificate T12801

The fulfillment of the essential requirements set out in Annex I and in the relevant instrument specific Annexes has been demonstrated.

The electricity meter types described above are in conformity with the relevant Union harmonization legislation and satisfy the appropriate requirements of the Directive 2014/32/EU with the following standards:
EN IEC 62052-11:2021/A11:2022. Electricity metering equipment – General requirements, tests and test conditions – Part 11: Metering equipment
EN50470-3:2022. Electricity metering equipment – Part 3: Particular requirements – Static meters for AC active energy (class indexes A, B and C)

This Declaration of Conformity is issued under the sole responsibility of the manufacturer.

Signed on behalf of

Signature: 浙江东传电子股份有限公司
ZHEJIANG EASTRON ELECTRONIC CO.,LTD.

Date: 2025/02/10

CONTACT US

If you have any question, please feel free to contact our sales team.

Address: NO 52, Dongjin Road, Nanhu, Jiaxing, Zhejiang, China

Tel: +86-573-83698881

Email: sales@eastrongroup.com

Web: www.eastrongroup.com

