

SDM230-WIFI TY

Single Phase Two Wires Multifunction DIN Rail Meter

User Manual

2025 V1.0



1. Introduction

The SDM230-WIFI TY measures and displays the characteristics of single phase two wire (1p2w) supplies, including voltage, frequency, current, power, active energy, reactive energy, imported energy, exported energy and total harmonic distortion. Energy is measured in terms of kWh, kVAh. SDM230-WIFI TY supports max. 100A direct connection. The SDM230-WIFI TY is equipped with a Wi-Fi communication function and supports communication with Tuya's "Smart Life" APP. The SDM230-WIFI TY is configured with 2 channels of pulse output. The pulse constant, pulse width and pulse type are configurable. Parameter configuration can be implemented via the buttons on the panel. It is well functional with high security.

1.1 Product Characteristics

- Multi-parameter measurement
- Direct connection up to 100A
- Support communication with AMR and SCADA systems
- Bidirectional energy metering IMP & EXP
- Wi-Fi function supported
- Support communication with Tuya "Smart Life" APP
- Din rail mounting 35mm
- LCD with white backlight, adjustable backlight time

1.2 Application Scenarios

The SDM230-WIFI TY is a multi-functional power meter designed for power monitoring in power systems, public utilities, industrial applications, residential buildings and other scenarios. It is applicable to power transmission and distribution, AC charging piles, solar photovoltaic systems and other occasions. Its comprehensive communication function makes it highly suitable for various real-time power monitoring systems.

2. Operation

2.1 LCD Display

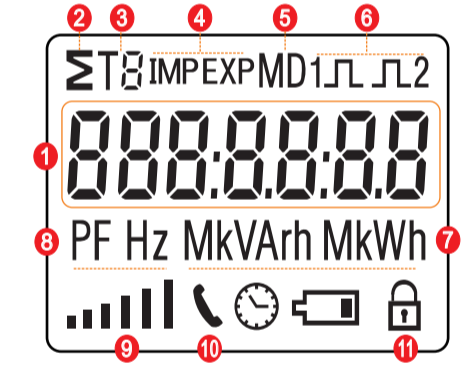

No.	Descriptions
1	7 digits used to display measured values
2	Total value
3	Tariff information
4	Import information, Export information
5	Max. Demand for power or current
6	Pulse output 1 and Pulse output 2
7	Measurement units
8	PF=power factor Hz=frequency
9	Bar display of power
10	Communication indicator
11	Lock symbol

2.2 Initialization Display

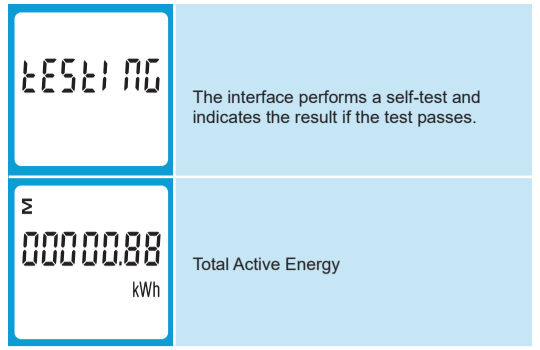
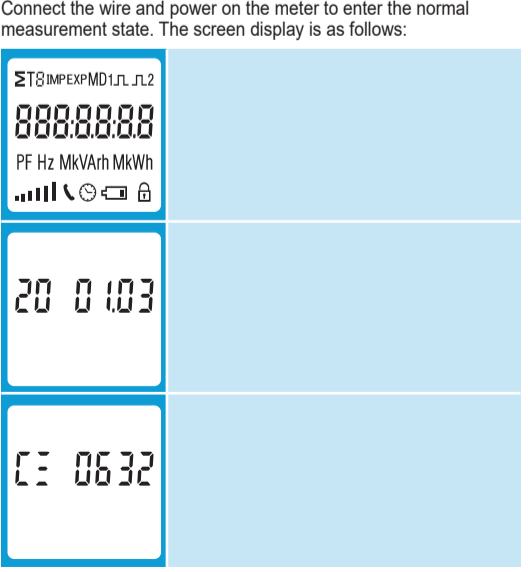

2.3 Button Functions

There are 2 keys on the panel, and the key operations are divided into two types: long press and short press: Long press: Press and hold the key for more than 3 seconds. Short press: Release the key within 1 second after pressing.

Button	Short click		Long press (3s)	
	Display mode	Setup mode	Display mode	Setup mode
[Wi-Fi]	Switch display screens	Next page or decrease value		Return to the previous menu
[Enter]		Move to right side	Enter Setup mode	Confirm setting

2.4 Measurements

Below parameters can be checked by pressing of the [Wi-Fi] button:

No.	Display	Descriptions
1		Total active energy in kWh
2		Imported active energy in kWh
3		Exported active energy in kWh
4		Total resettable energy in kWh
5		Total reactive energy in kVAh
6		Import reactive energy in kVAh
7		Export reactive energy in kVAh
8		Total resettable reactive energy in kVAh
9		Total Max. power demand
10		Voltage
11		Current
12		Active Power

13		Reactive Power
14		Apparent power
15		Power factor
16		Frequency
17		Running time
18-1		Network Configuration State: Network configuration was not completed, or the device has re-entered the pairing mode.
18-2		WIFI State: Network Configured - Awaiting Internet Connection.
18-3		Upload Data State: Internet connection successful. Device is now reporting data. Note: The Wi-Fi icon in the upper-right corner of the screen indicates the current signal strength. It displays 1 to 6 bars; more bars represent a stronger Wi-Fi signal.
19		WIFI Module Firmware Version Number.
16		Active power Example: 4700W
17		Reactive power Example: 1030VAr
18		Apparent power Example: 4811VA
19		Power factor Example: 1.000

2.5 Setup Mode

The meter's settable parameters have password protection. Long pressing on the [Enter] button to enter setup mode. Some menu items require a four-digit number entry while others, such as supply system, require selection from a number of menu options.

- Setting Mode Key Operation Instructions:
1. Long press Key [Enter], enter the password, then long press again to access the setting interface.
 2. Short press Key [Wi-Fi] to select the desired setting menu.
 3. Long press Key [Enter] to enter the modification interface for that setting. Short press Key [Wi-Fi] to select the desired option, then long press Key [Enter] again to confirm.
 4. Long press Key [Wi-Fi] to exit the setting interface.

Settings interface	Set status	Optional configuration
		Password Accessing the setting interface requires password entry. Default: 1000
		Pulse Type Option: Export kWh, kWh, Import kWh, Export kVAh, kVAh, Import kVAh. Default: kWh

Settings interface	Set status	Optional configuration
		Pulse Constant Option: 1, 10, 100, 1000Imp/kWh Default: 1000Imp/kWh
		Pulse Width Option: 200, 100, 60mS Default: 100mS
		Demand interval time setting Option: 0, 5, 10, 15, 20, 30, 60min Default: 60min
		Automatic Scroll Time Interval Option: 0 - 255S Default: 0S (Does not automatically turn pages)
		Backlit time setting Option: ON, 5, 10, 20, 30, 60, 120, OFF Default: 60
		CLR max demand setting
		Clear the resettable energy
		Password setting Range: 0000~9999 Default: 1000
		Enter NET SET Mode
		Exit NET SET Mode

3. Specifications

3.1 General Specifications

- Voltage AC(Un) 230V
- Voltage range 100-277VAC
- Base current(Ib/Ifref) 10A AC
- Max.current(I_{max}) 100A AC
- Mini current (I_{min}) 0.15A AC
- Starting Current (I_{st}) 0.04A
- Power consumption <2W/10VA
- Frequency 50/60Hz
- AC voltage withstand 4KV for 1 min
- Impulse voltage withstand 6kV - 1.2/50μS waveform
- Over current withstand 30 I_{max} for 0.01s
- Pulse 1 output rate configurable(default 400imp/kWh)
- Pulse 2 output rate non-configurable, 400imp/kWh
- Display LCD with backlight
- Max.reading 99999.99 kWh/kVAh

3.2 Accuracy

- Voltage ±0.2%
- Current ±0.2%
- Frequency ±0.05%
- Active power ±0.5% (10%I_b-I_{max})
- Reactive power ±1% (10%I_b-I_{max})
- Apparent power ±0.5% (10%I_b-I_{max})
- Active energy Class 0.5 IEC62053-21
Class C EN50470-3:2022 (MID version only)
- Reactive energy Class 2 IEC 62053-23

3.3 Environment

- Operating temperature -40°C to +70°C
- Storage Temperature -40°C to +80°C
- Reference temperature 23°C ± 2°C
- Relative humidity 0 to 95%, non-condensing
- Mechanical environment M1
- Electromagnetic environment E2
- Pollution Degree II
- Altitude ≤2000m
- Vibration 10Hz ~ 50Hz, IEC 60068-2-6

3.4 Mechanics

- Din rail dimensions 36x100x63 (WxHxD) Per DIN 43880
- Mounting DIN rail 35mm
- Ingress protection IP51 Front Display/IP20 Whole Meter
- Material Self-extinguishing UL94V-0

3.5 Safety

- Measurement Category Per IEC61010-1 CAT III
- Installation Category CAT III
- Over-voltage Category CAT III
- Protective Class II

3.6 Interface(Wi-Fi 2.4G)

RF Band	2.412-2.484GHz
Max. RF Power	<17 dBm
Wi-Fi Protocol	802.11 b/g/n
Wi-Fi Range	Up to 30m / 100ft indoors and 50m / 160ft outdoors (Depends on local conditions)

3.8 Pulse Output 1(configurable)

Pulse Type	Import Active Energy, Total Active Energy, Export Active Energy, Import Reactive Energy, Total Reactive Energy, Export Reactive Energy(default).
Pulse Constant	0.01, 0.1, 1, 10, 100, 400 (default) Imp/kWh
Pulse Width	200, 100(default), 60mS

3.9 Pulse Output 2(non-configurable)

Pulse Type	Total Active Energy
Pulse Constant	400Imp/kWh
Pulse Width	100mS

4. Connecting to the "Smart Life" APP

4.1 Initial State Description

The meter is not pre-configured with a Wi-Fi network during production. After the first power-on, the meter automatically enters the network configuration mode. At this time, the Wi-Fi status interface of the meter is displayed as shown in Figure 1.



Figure 1

4.2 Adding a Device

Automatic Discovery:
Open the Tuya "Smart Life" APP. If the "Device to be added" pop-up window appears (as shown in Figure 2), click "Add".

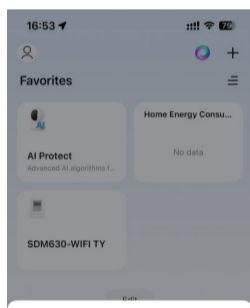

Figure 2

Manual Addition:
If no prompt window pops up: Click the "+" icon at the top right corner of the APP's homepage. Select "Add Device". Tap the corresponding meter icon to enter the manual addition process (as shown in Figure 3).

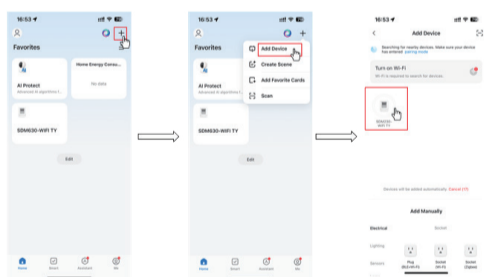

Figure 3

4.3 Wi-Fi Network Configuration

From the Wi-Fi list provided in the APP, select your network name. Enter the password and confirm. The meter will start connecting to the network (as shown in Figure 4) and enters the Wi-Fi connection state. Its Wi-Fi status interface is displayed as shown in Figure 5.

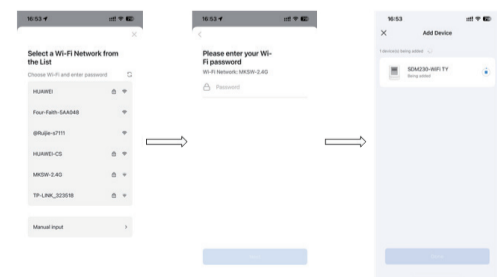

Figure 4



Figure 5

4.4 Post-Connection Confirmation

After successful network connection, the meter enters the data reporting mode, and its Wi-Fi status interface is displayed as shown in Figure 6.

A "Wi-Fi" icon will appear next to the corresponding device name in the APP, indicating successful connection. Click "Finish" to access the APP's device details page, which will synchronously display the real-time parameters uploaded by the meter (as shown in Figure 7).



Figure 6

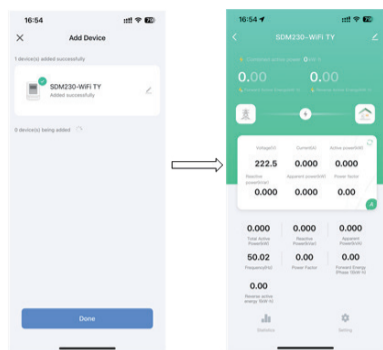

Figure 7

4.5 Device Management

Viewing Devices

The list of added devices is available on the APP's homepage. Click the corresponding device icon to enter the details page and view detailed parameters (as shown in Figure 8).

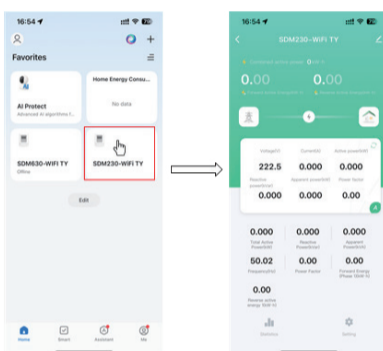

Figure 8

Deleting Devices:

On the device details page, click the "Edit" icon at the top right corner. Select "Remove Device" in the edit page to delete the current device from the APP (as shown in Figure 9).

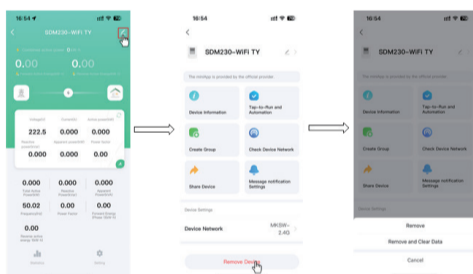

Figure 9

5. Safety Instruction

Information for Your Own Safety

Important safety information is contained in the maintained section. Familiarize yourself with this information before attempting installation or other procedures. Symbols used in this documents:

Risk of Danger
This means to call attention to a high risk, for example: "High voltage". Failure to observe the instruction can result in death, serious injury or considerable material damage.

Caution
This means hazard of electric shock and failure to take thenecessary safety precautions will result in death, serious injury or considerable material damage.

Qualified Personnel

Operation of the equipment (module, device) described in this manual may only be performed by qualified personnel. Qualified personnel in this manual means person who are authorized to commission, start up, ground and label devices, systems and circuits according to safety and regulatory standards. The installer is responsible for coordinating the rating and the characteristics of the supply side overcurrent protection devices with the maximum current rating and, in the case of direct connected meters, with the UC rating of the metering equipment.

Proper Handling

The equipment (device, module) may only be used for the application specified in the catalogue and the user manual, and only be connected with devices and components recommended and approved by EASTRON.

- The unit does not have internal fuses therefore external fuses must be used for protection and safety under fault conditions.
- Use only insulating tools.
- Do not connect while circuit is live (hot).
- Place the meter only in dry surroundings.
- Do not mount the meter in an explosive area or expose the meter to dust, mildew and insects.
- Make sure the used wires are suitable for the maximum current of this meter.
- Make sure the AC wires are connected correctly before activating the current/voltage to the meter.
- Do not touch the meter connecting clamps directly with your bare hands, with metal, blank wire or other material as you may get an electrical shock.
- Make sure the protection cover is placed after installation.

- Installation, maintenance and reparation should only be done by qualified personnel.
- Never break the seals and open the front cover as this might influence the functionality of the meter, and will void any warranty.
- Do not drop, or allow physical impact to the meter as there are high precision components inside that may break.
- An external switch or circuit-breaker should be installed on the power supply wires, which will be used to disconnect the meter and the device supplying energy. It is recommended that this switch or circuit-breaker is placed near the meter because that is more convenient for the operator. The switch or circuit-breaker must comply with the specifications of the building' selectrical design and all local regulations

5.1 Maintenance

In normal use, little maintenance is needed. As appropriate for service conditions, isolate electrical power, inspect the unit and remove any dust or other foreign material present. Periodically check all connections for freedom from corrosion and screw tightness, particularly if vibration is present. The front of the case should be wiped with a dry cloth only. Use minimal pressure, especially over the viewing window area. If necessary wipe the rear case with a dry cloth. If a cleaning agent is necessary, isopropyl alcohol is the only recommended agent and should be used sparingly. Water should not be used. If the rear case exterior or terminals should be contaminated accidentally with water, the unit must be returned to EASTRON for inspection and testing.

6. Dimensions

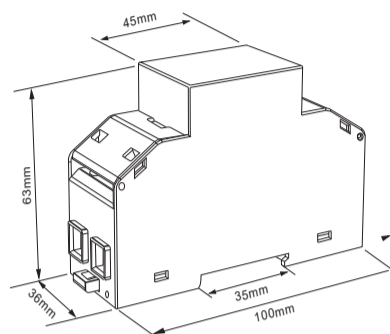

7. Mounting

- Step 1: Select a 35mm-wide DIN rail, Pull down the back-end clip on the meter to unlock the mounting mechanism.
- Step 2: Align Upper Slot with DIN Rail. Position the upper slot of the meter's DIN rail groove onto the DIN rail, ensuring full contact (see Figure 1).
- Step 3: Following the direction indicated in Figure 1, engage the lower slot of the DIN rail groove onto the DIN rail until audibly seated (see Figure 2).
- Step 4: Push up the back-end clip to lock the meter firmly onto the DIN rail (see Figure 3).

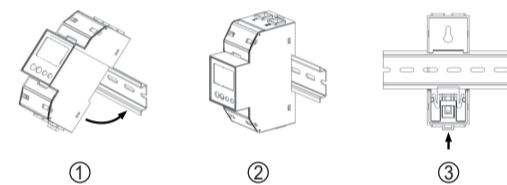

8. Wiring Diagram

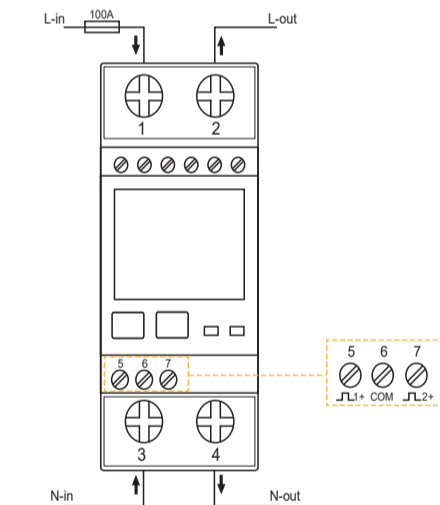

8.2 Wiring Guide

Terminal	Measurement Connection	Screw Connection
Terminal ①~④	Strip Length	17-18mm
	Screw	M7
	Rigid/Supple	4-35mm ² (11~2 AWG)
	Tightening Torque	3Nm
	Model	PH3
Terminal (B, A, B2, A2)	Measurement Connection	Screw Connection
	Strip Length	5-6mm
	Rigid/Supple	0.5-1.5mm ² (22~14AWG)
	Tightening Torque	0.4Nm
	Model	PH0

8. Declaration of Conformity(for the MID approved version meter only)

We Zhejiang Eastron Electronic Co.,Ltd.
Declare under our sole responsibility as the manufacturer that the single phase multifunction electrical meter "SDM230 series" correspond to the production model described in the EU-type examination certificate and to the requirements of the Directive 2014/32/EU.
Type examination certificate number MID T12800.
Identification number of the NB0598.

CONTACT US

If you have any question, please feel free to contact our sales team.

Address: NO 52, Dongjin Road, Nanhu, Jiaxing, Zhejiang, China

Tel: +86-573-83698881

Email: sales@eastrongroup.com

Web: www.eastrongroup.com

Eastron