

SDM630-WiFi TY

Smart Three Phase Energy Meter

User Manual

2025 V1.0



1. Introduction

The SDM630-WiFi TY measures and displays the characteristics of single phase two wire (1p2w), single phase three wire (1p3w), three phase three wire (3p3w) and three phase four wire (3p4w) supplies, including voltage, frequency, current, power, active energy, reactive energy, imported energy, exported energy and total harmonic distortion. Energy is measured in terms of kWh, kVAh. SDM630-WiFi TY supports max. 100A direct connection. The SDM630-WiFi TY is equipped with a Wi-Fi communication function and supports communication with Tuya's "Smart Life" APP.

The SDM630-WiFi TY is configured with 2 channels of pulse output. The pulse constant, pulse width and pulse type are configurable. Parameter configuration can be implemented via the buttons on the panel. It is well functional with high security.

1.2 Product Characteristics

- Multi-parameter measurement
- Direct connection up to 100A
- Support communication with AMR and SCADA systems
- Bidirectional energy metering IMP & EXP
- Wi-Fi function supported
- Support communication with Tuya "Smart Life" APP
- Din rail mounting 35mm
- LCD with white backlight, adjustable backlit time

1.3 Application Scenarios

The SDM630-WiFi TY is a multi-functional power meter designed for power monitoring in power systems, public utilities, industrial applications, residential buildings and other scenarios. It is applicable to power transmission and distribution, AC charging piles, solar photovoltaic systems and other occasions. Its comprehensive communication function makes it highly suitable for various real-time power monitoring systems.

2. Specification

2.1 Energy Measurements

- Import active energy 0 to 999999.99 kWh
- Export reactive energy 0 to 999999.99 kVAh
- Import active energy 0 to 999999.99 kWh
- Export reactive energy 0 to 999999.99 kVAh
- Total active energy 0 to 999999.99 kWh
- Total reactive energy 0 to 999999.99 kVAh

2.2 Measured Inputs

Voltage inputs through 4-way fixed connector with 25mm² stranded wire capacity, single phase two wires (1p2w), three phase three wires (3p3w) or three phase four wires (3p4w) unbalanced. Line frequency measured from L1 voltage or L3 voltage.

- Voltage AC(Un) 3*230V(L-N)/400V(L-L)
- Voltage Range 100-277 V AC (L-N)
100-480 V AC (L-L)
- Base Current (Ib) 10A AC
- Max.Current (Imax) 100A AC
- Min.Current (Imin) 0.3A
- Starting current 0.04A
- Transition Current (Itr) 1A
- Over Current Withstand 30Imax for 0.01S
- AC Voltage Withstand 4KV/1min
- Impulse Voltage Withstand 6kV - 1.2/50μS waveform
- Power consumption ≤2W/10VA(Voltage Circuit)
≤0.05VA(Current Circuit)
- Display LCD with white backlight
- Max. reading 999999.99 kWh/kVAh

2.3 Accuracy

- Voltage ±0.2%
- Current ±0.2%
- Frequency ±0.05%
- Power factor ±0.005
- Active power (W) ± 0.5% (10%Ib-Imax)
- Reactive power (VA) ± 1% (10%Ib-Imax)
- Apparent power (VA) ± 0.5% (10%Ib-Imax)
- Active energy (Wh) Class 0.5 IEC 62053-21;
Class C EN 50470-3:2022 (MID version)
- Reactive energy (VAh) Class 2 IEC 62053-23
- Response time to step input 1s, typical, to >99%offinal reading, at 50 Hz.

2.4 Measured Inputs

Influence Quantities are variables that affect measurement errors to a minor degree. Accuracy is verified under nominal value (within the specified tolerance) of these conditions.

- Ambient temperature 23°C±2°C
- Input frequency 50 or 60Hz±2%
- Input waveform Sinusoidal (distortion factor<0.005)
- Magnetic field of external origin Terrestrial flux

2.5 Environment

- Operating temperature -40°C to +70°C
- Storage temperature -40°C to +80°C
- Operation humidity ≤90%, non-condensing
- Storage humidity ≤95%, non-condensing
- Pollution Degree ≤2000m
- Altitude II
- Vibration 10Hz ~ 50Hz, IEC 60068-2-6
30g in 3 planes

*Maximum operating and storage temperatures are in the context of typical daily and seasonal variation.

2.6 Mechanics

- Dimensions 100x72x66mm (WxHxD)
- Mounting DIN rail (DIN35mm)
- IP Degree of Protection IP51 Front Display
IP20 Whole Meter
- Material of Meter Case Self-extinguishing UL94 V-0

2.7 Pulse Output

The meter is equipped with pulse output, which is fully isolated from the inside circuit. That generates pulses in proportion to the measured energy. The pulse output is polarity dependent, passive transistor output requiring an external voltage source for correct operation.

For this external voltage source, the voltage shall be 5-27V DC, and the maximum input current shall be 27mA DC.

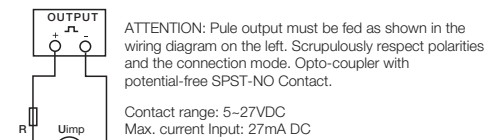

Pulse Output

The meter provides two pulse outputs. Both pulse outputs are passive type.

Pulse output 1 is configurable. The pulse output can be set to generate pulses to represent total / import / export kWh or kVAh.

The pulse constant can be set to generate 1 pulse per: 0.01, 0.1, 1, 10, 100, 400 (default) Imp/kWh

Pulse width: 200, 100(default), 60mS

Pulse output 2 is non-configurable. It is fixed to import kWh. The constant is 400Imp/kWh.

Wi-Fi support: 2.4Ghz b/g/n

Wi-Fi data freq.: Every second

2.8 LCD Display

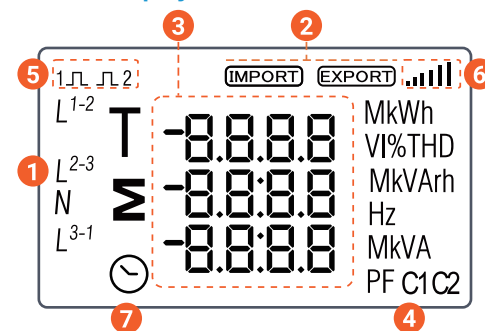

Item	Descriptions
1	Total, fuses or sum
2	Import or Export energy
3	Measured value (8 digits)
4	Measurement units
5	Pulse 1 and 2
6	Wi-Fi signal strength
7	Time identifier

3. Operation

3.1 Installation Display

After correct wiring, power on the meter to enter the normal measurement state. The screen display is as follows:

The first screen lights up all display segments and can be used as a display check.

The second screen and the third screen indicates the firmware installed in the unit. Note: the actual display might be different with the left on here.

The interface performs a self-test and indicates the result if the test passes.

Total Active Energy

3.1 Button Functions

There are 4 keys on the panel, and the key operations are divided into two types: long press and short press:
Long press: Press and hold the key for more than 3 seconds.
Short press: Release the key within 1 second after pressing.

- U/I ESC**: Selects the Voltage and Current display screens. In Set-up Mode, this is the "Left" or "Back" button.
- M**: Select the Frequency and Power factor display screens. In Set-up Mode, this is the "Up" button.
- P**: Select the Power display screens. In Set-up Mode, this is the "Down" button.
- E**: Select the Energy display screens. In Set-up mode, this is the "Enter" or "Right" button.

3.2 Voltage and Current

Below parameters can be checked by pressing the **U/I** button:

- Phase to neutral voltages. *Not available under 3P3W
- Phase to phase voltages. *Not available under 1P2W
- Current on each phase.
- Phase to neutral voltage THD% *Phase to phase voltage THD% under 3P3W
- Phase current THD%

3.3 Frequency and Power Factor and Demand

Below parameters can be checked by pressing the **M** button:

- Frequency and Power Factor (total).
- Power Factor of each phase. *Not available under 3P3W, 1P2W.
- Maximum current demand of each phase
- Maximum total power demand

3.4 Power

Below parameters can be checked by pressing the **P** button:

- Instantaneous Active Power in kW. *Not available under 3P3W, 1P2W.
- Instantaneous Reactive Power in kVAh. *Not available under 3P3W, 1P2W.
- Instantaneous Volt-Amps in kVA. *Not available under 3P3W, 1P2W.
- Total kW, kVAh, kVA.

3.5 Energy, WIFI

Below parameters can be checked by pressing of the **E** button:

- Total active energy in kWh.
- Total reactive energy in kVAh
- Imported active energy in kWh
- Exported active energy in kWh
- Imported reactive energy in kVAh
- Exported reactive energy in kVAh

- Exported reactive energy in kVAh
- Network Configuration State: Network configuration was not completed, or the device has re-entered pairing mode.
- WiFi State: Network Configured - Awaiting Internet Connection.
- Upload Data State: Internet connection successful. Device is now reporting data. Note: The Wi-Fi icon in the upper-right corner of the screen indicates the current signal strength. It displays 1 to 6 bars; more bars represent a stronger Wi-Fi signal.
- WiFi Module Firmware Version Number.

3.6 Setup Mode

The meter's settable parameters have password protection. Long pressing on the **E** button can access to the enter setup mode. Some menu items require a four-digit number entry while others, such as supply system, require selection from a number of menu options.

3.7 Menu Option Selection

1. Use the **U/I** and **M** buttons to scroll through the different options of the set up menu.
2. Press **M** to confirm your selection.
3. If an item flashes, then it can be adjusted by the **U/I** and **M** buttons.
4. Having selected an option from the current layer, press **M** to confirm your selection.
5. After parameter setting, press **U/I** to return to a previous menu, then you can use the **U/I** and **M** buttons for more menu selection.
6. After setting-up, press **E** repeatedly to return to the home screen.

3.8 Number Entry Procedure

In setting mode, some screens require to enter numbers or passwords. Normally, it follows the rule of left to right. The procedure is as follows:

1. When the numer flashes, use **U/I** and **M** buttons to select the number.
2. Short press **M** to confirm the digit setting and move to the next.
3. After setting the last digit, long press **M** to confirm the setting.
4. Press **U/I** to return to a previous menu.

3.9 Setting Menu

- Set status**: Password (Default: 1000)
- Settings interface**: Pulse Type (Option: EXPORT kWh, kWh, IMPORT kWh, EXPORT kVAh, kVAh, IMPORT kVAh, kVAh. Default: EXPORT kVAh)
- Set status**: Pulse Constant (Option: dFt, 0.01, 0.1, 1, 10, 100, 400Imp/kWh. Default: 400Imp/kWh)
- Settings interface**: Pulse Width (Option: 200, 100, 60mS. Default: 100mS)

Settings interface

Set status

Demand interval time
Setting
Option: 0, 5, 8, 10, 15, 20, 30, 60min
Default: 60min

Settings interface

Set status

System type setting
Option: 3P4W, 3P3W, 1P2W
Default: 3P4W

Settings interface

Set status

CLR max demand setting

Settings interface

Set status

Password setting
Range: 0000-9999
Default: 1000

Settings interface

Set status

Enter NET SET Mode

Settings interface

Set status

Exit NET SET Mode

• Manual Addition:
If no prompt window pops up:
Click the "+" icon at the top right corner of the APP's homepage. Select "Add Device". Tap the corresponding meter icon to enter the manual addition process (as shown in Figure 3).

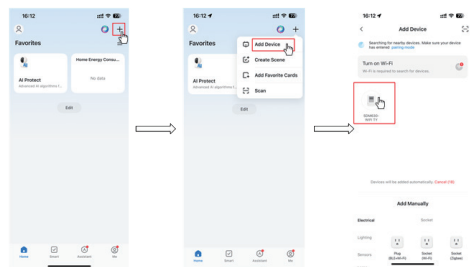

Figure 3

4.3 Wi-Fi Network Configuration

From the Wi-Fi list provided in the APP, select your network name. Enter the password and confirm. The meter will start connecting to the network (as shown in Figure 4) and enters the Wi-Fi connection state. Its Wi-Fi status interface is displayed as shown in Figure 5.

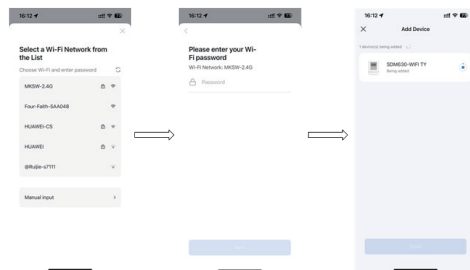

Figure 4

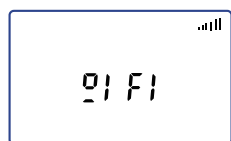

Figure 5

4.4 Post-Connection Confirmation

After successful network connection, the meter enters the data reporting mode, and its Wi-Fi status interface is displayed as shown in Figure 6.

A "✔" icon will appear next to the corresponding device name in the APP, indicating successful connection. Click "Finish" to access the APP's device details page, which will synchronously display the real-time parameters uploaded by the meter (as shown in Figure 7).



Figure 6

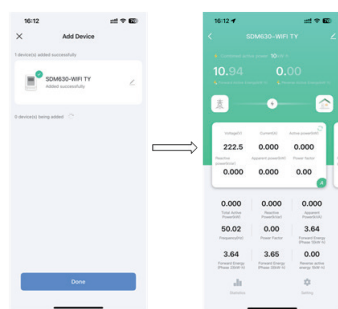

Figure 7

4.5 Device Management

• Viewing Devices
The list of added devices is available on the APP's homepage. Click the corresponding device icon to enter the details page and view detailed parameters (as shown in Figure 8). Swipe left or right to check the phase-specific information of Phase A, Phase B, and Phase C (as shown in Figure 9).

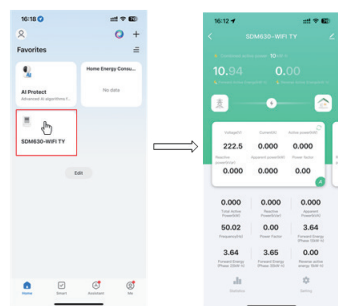

Figure 8

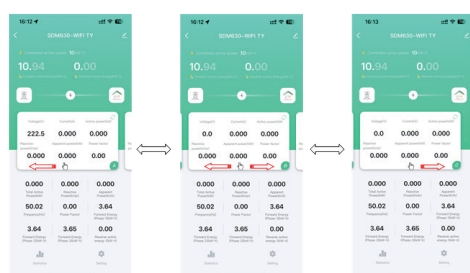

Figure 9

4. Connecting to the "Smart Life" APP

4.1 Initial State Description

The meter is not pre-configured with a Wi-Fi network during production. After the first power-on, the meter automatically enters the network configuration mode. At this time, the Wi-Fi status interface of the meter is displayed as shown in Figure 1.



Figure 1

4.2 Adding a Device

• Automatic Discovery:
Open the Tuya "Smart Life" APP. If the "Device to be added" pop-up window appears (as shown in Figure 2), click "Add".

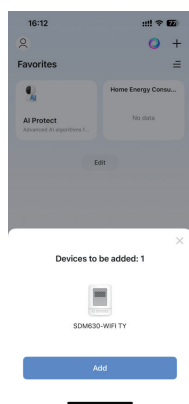

Figure 2

• Deleting Devices:
On the device details page, click the "Edit" icon at the top right corner. Select "Remove Device" in the edit page to delete the current device from the APP (as shown in Figure 10).

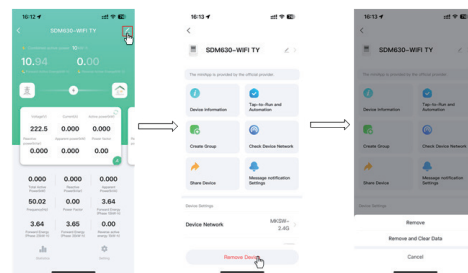

Figure 10

5. Installation

5.1 Safety Instruction

Information for Your Own Safety

Important safety information is contained in the maintained section. Familiarize yourself with this information before attempting installation or other procedures. Symbols used in this documents:



Risk of Danger

This means to call attention to a high risk, for example: "High voltage". Failure to observe the instruction can result in death, serious injury or considerable material damage.



Caution

This means hazard of electric shock and failure to take the necessary safety precautions will result in death, serious injury or considerable material damage.

Qualified Personnel

Operation of the equipment (module, device) described in this manual may only be performed by qualified personnel. Qualified personnel in this manual means person who are authorized to commission, start up, ground and label devices, systems and circuits according to safety and regulatory standards. The installer is responsible for coordinating the rating and the characteristics of the supply side overcurrent protection devices with the maximum current rating and, in the case of direct connected meters, with the UC rating of the metering equipment.

Proper Handling

The equipment (device, module) may only be used for the application specified in the catalogue and the user manual, and only be connected with devices and components recommended and approved by EASTRON.

- The unit does not have internal fuses therefore external fuses must be used for protection and safety under fault conditions.
- Use only insulating tools.
- Do not connect while circuit is live (hot).
- Place the meter only in dry surroundings.
- Do not mount the meter in an explosive area or expose the meter to dust, mildew and insects.
- Make sure the used wires are suitable for the maximum current of this meter.
- Make sure the AC wires are connected correctly before activating the current / voltage to the meter.
- Do not touch the meter connecting clamps directly with your bare hands, with metal, blank wire or other material as you may get an electrical shock.
- Make sure the protection cover is placed after installation.
- Installation, maintenance and reparation should only be done by qualified personnel.
- Never break the seals and open the front cover as this might influence the functionality of the meter, and will avoid any warranty.
- Do not drop, or allow physical impact to the meter as there are high precision components inside that may break.
- An external switch or circuit-breaker should be installed on the power supply wires, which will be used to disconnect the meter and the device supplying energy. It is recommended that this switch or circuit-breaker is placed near the meter because that is more convenient for the operator. The switch or circuit-breaker must comply with the specifications of the building's selectrical design and all local regulations

5.2 Maintenance

In normal use, little maintenance is needed. As appropriate for service conditions, isolate electrical power, inspect the unit and remove any dust or other foreign material present. Periodically check all connections for freedom from corrosion and screw tightness, particularly if vibration is present. The front of the case should be wiped with a dry cloth only. Use minimal pressure, especially over the viewing window area. If necessary wipe the rear case with a dry cloth. If a cleaning agent is necessary, isopropyl alcohol is the only recommended agent and should be used sparingly. Water should not be used. If the rear case exterior or terminals should be contaminated accidentally with water, the unit must be returned to EASTRON for inspection and testing

6. Dimensions

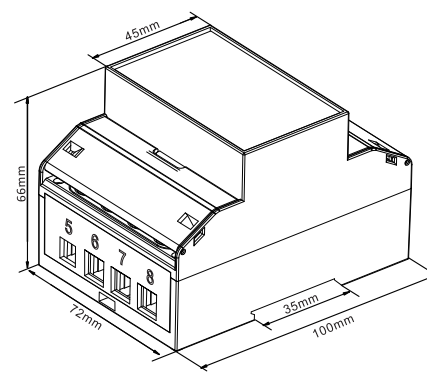

7 Mounting

- Step 1: Select a 35mm-wide DIN rail. Pull down the back-end clip on the meter to unlock the mounting mechanism.
- Step 2: Align Upper Slot with DIN Rail. Position the upper slot of the meter's DIN rail groove onto the DIN rail, ensuring full contact (see Figure 1).
- Step 3: Following the direction indicated in Figure 1, engage the lower slot of the DIN rail groove onto the DIN rail until audibly seated (see Figure 2).
- Step 4: Push up the back-end clip to lock the meter firmly onto the DIN rail (see Figure 3).

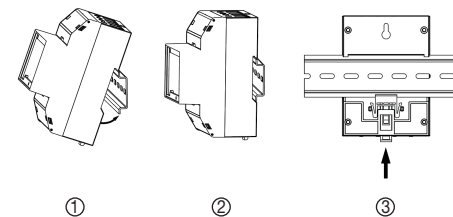

8. Wiring Diagram

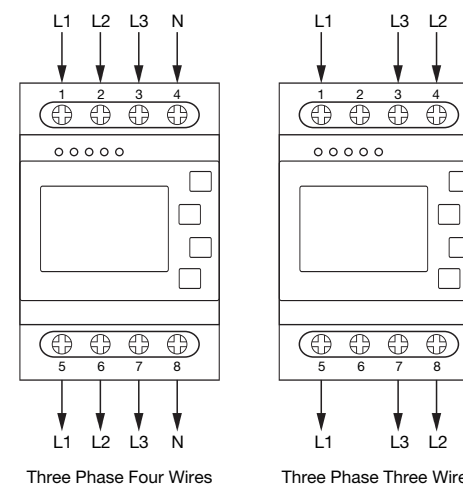
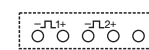

Three Phase Four Wires

Three Phase Three Wires

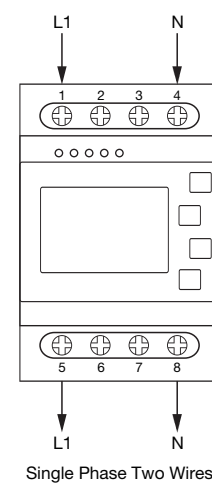

Single Phase Two Wires

* For reverse wiring needs, kindly notify our sales team before placing an order

8.2 Wiring Guide

Terminal	Measurement Connection	Screw Connection
	Terminal ① ~ ④	Strip Length Strip Length Screw Rigid/Supple Tightening Torque Model
Terminal (B, A, B2, A2)	Measurement Connection Strip Length Rigid/Supple Tightening Torque Model	Screw Connection 5-6mm 0.5-1.5mm ² (26-14AWG) 0.4Nm PH0

9. Declaration of Conformity (for the MID approved version meter only)

We Zhejiang Eastron Electronic Co.,Ltd. Declare under our sole responsibility as the manufacturer that the poly phase multifunction electrical meter "SDM630-WIFI" correspond to the production model described in the EU-type examination certificate and to the requirements of the Directive 2014/32/EU. Type examination certificate number MID T12801. Identification number of the NB0598.

CONTACT US

If you have any question, please feel free to contact our sales team.

Address: NO 52, Dongjin Road, Nanhu, Jiaxing, Zhejiang, China
Tel: +86-573-83698881
Email: sales@eastrongroup.com
Web: www.eastrongroup.com



DH-SMS-0602